

244

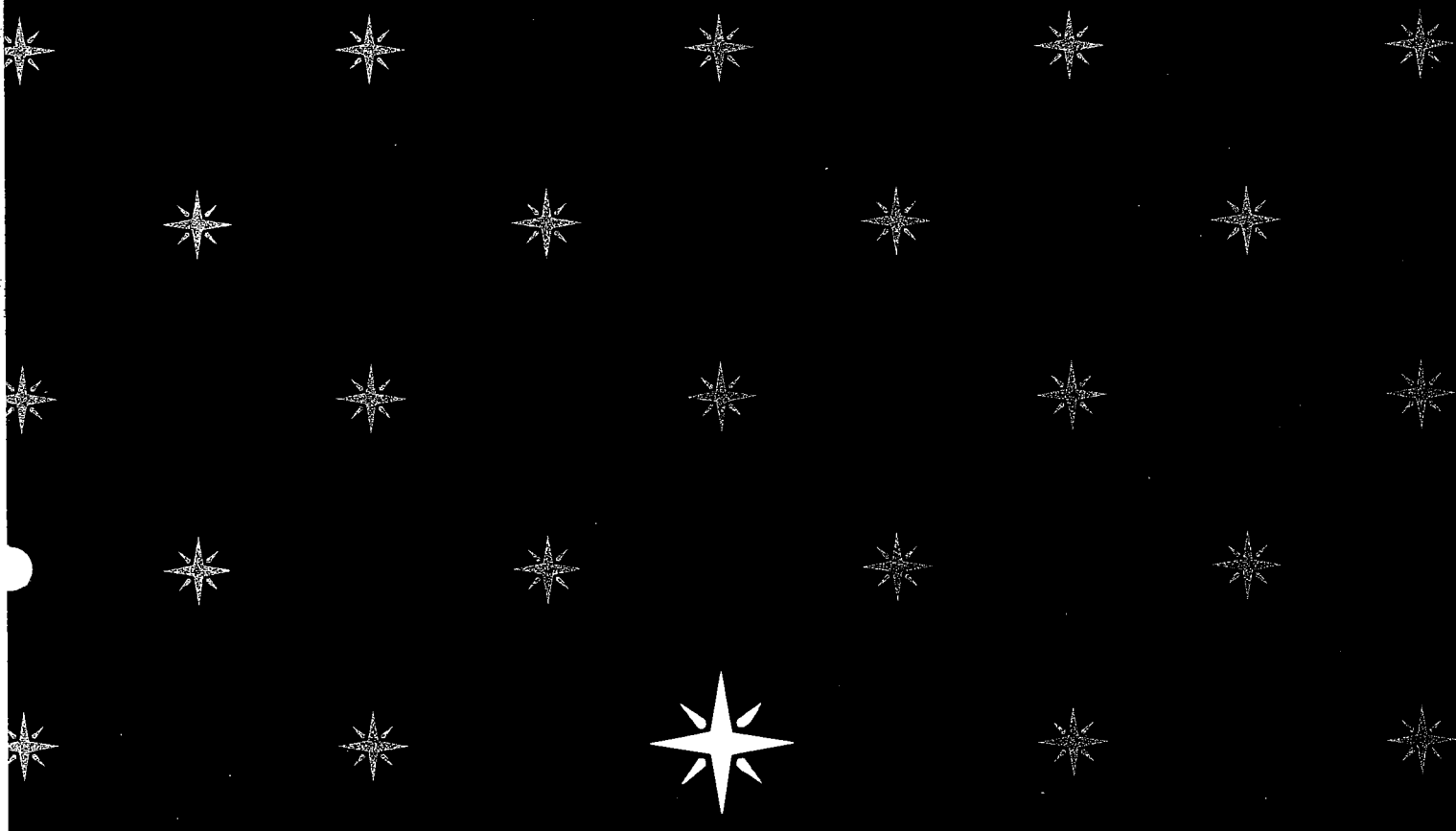

**SERVICE
MANUAL 2250**



marantz

model 2250

Stereophonic Receiver

TABLE OF CONTENTS

SECTION	PAGE
Introduction	1
P.W. Board	1
Test Equipment Required for Servicing	2
AM Alignment Procedure	2
FM Alignment Procedure	3
Stereo Separation Alignment	3
Muting Circuit Alignment	3
Dolby FM Tape Output Setting	4
Audio Adjustment	4
Technical Specifications (for U.S.A. Model)	25
Parts List	27
Service Information for European Model	38
Technical Specifications (for European Model)	38

LIST OF ILLUSTRATIONS

FIGURE	PAGE
1. Dial Stringing	4
2. Wiring Diagram	5
3. Schematic Diagram	6
4. Exploded Mechanical Diagram	8
5. Front Panel Adjustments and Component Locations	10
6. Main Chassis Component Locations (Top View)	10
7. Rear Panel Adjustment and Component Locations	11
8. Main Chassis Component Locations (Bottom View)	11
9. FM Front End(P100) Schematic Diagram and Component Locations	12
10. AM Tuner (P150) Schematic Diagram and Component Locations	13
11. FM IF (P200) Schematic Diagram and Component Locations	14
12. FM MPX (P300) Schematic Diagram and Component Locations	15
13. Ant. Muting (PU01) Schematic Diagram and Component Locations	16
14. Phono Amplifier (P400) Schematic Diagram and Component Locations	17
15. Dial Lamp (PZ01) Schematic Diagram and Component Locations	18
16. Function Lamps Assembly (PY01) Schematic Diagram and Component Locations	18
17. Monitor (PT01) Schematic Diagram and Component Locations	19
18. Pre Tone Amplifier (PE01) Schematic Diagram and Component Locations	20
19. Filter (PH01) Schematic Diagram and Component Locations	21
20. Main Amplifier (P700) Schematic Diagram and Component Locations	22
21. Power Supply (P800) Schematic Diagram and Component Locations	23
22. Dolby FM Assembly (PC01) Schematic Diagram and Component Locations	24
23. Packing	26
24. Rear Panel Adjustments and Component Locations for European Model	40
25. Main Chassis Component Locations (Bottom View) for European Model	40
26. Voltage Conversion Chart	41
27. Schematic Diagram for European Model	42

INTRODUCTION

This service manual was prepared for use by Authorized Warranty Stations and contains service information for Marantz Model 2250 Stereophonic Receiver.

Servicing information and voltage data included in this manual are intended for use by the knowledgeable and experienced technician only. All instructions should be read carefully. No attempt should be made to proceed without a good understanding of the operation of the receiver.

The parts list furnishes information by which replacement parts may be ordered from the Marantz Company. A simple description is included for parts which can usually be obtained through local suppliers.

1. P.W. Board

As can be seen from the circuit diagram the chassis of Model 2250 consists of the following units. Each unit mounted on a printed circuit board is described within the square enclosed by a bold dotted line on the circuit diagram.

1. FM Front End	Mounted on P.W. Board, P100
2. AM Tuner	Mounted on P.W. Board, P150
3. FM — IF	Mounted on P.W. Board, P200
4. MPX	Mounted on P.W. Board, P300
5. ANT. Muting VR	Mounted on P.W. Board, PU01
6. Dolby Level	Mounted on P.W. Board, PC01
7. Phono Amp.	Mounted on P.W. Board, P400
8. Dial Lamp	Mounted on P.W. Board, PZ01
9. Monitor, SW	Mounted on P.W. Board, PT01
10. Function Lamp	Mounted on P.W. Board, PY01
11. Pre Tone Amp.	Mounted on P.W. Board, PE01
12. Filter, SP SW	Mounted on P.W. Board, PH01
13. Power Amp.	Mounted on P.W. Board, P700
14. Power Supply	Mounted on P.W. Board, P800

2. TEST EQUIPMENT REQUIRED FOR SERVICING

Table 1 lists the test equipment required for servicing the Model 2250 Receiver.

Item	Manufacturer and Model No.	Use
AM Signal Generator		Signal source for AM alignment.
Test Loop		Used with AM signal generator.
FM Signal Generator	Less than 0.3% distortion	Signal source for FM alignment.
Stereo Modulator	Less than 0.3% distortion	Stereo separation alignment and trouble shooting.
Frequency Counter		MPX Oscillator adjustment (VCO).
Audio Oscillator	Weston Model CVO-100P, less than 0.02% residual distortion is required	Sinewave and squarewave signal source.
Oscilloscope	High sensitivity with DC horizontal and vertical amplifiers	Waveform analysis and trouble shooting and ASO alignment.
VTVM	With AC, DC, RF range	Voltage measurements.
Circuit Tester		Trouble shooting.
AC Wattmeter	Simpson, Model 390	Monitors primary power to amplifier.
AC Ammeter	Commercial Grade (1-10A)	Monitors amplifier output under short circuit condition.
Line Voltmeter	Commercial Grade (0-150V AC)	Monitors potential of primary power to amplifier.
Variable Autotransformer (0-140V AC, 10 amps)	Powerstat, Model 116B	Adjusts level of primary power to amplifier.
Shorting Plug	Use phono plug with 600 ohm across center pin and shell.	Shorts amplifier input to eliminate noise pickup.
Output load (8 ohms, $\pm 1\%$ 100W)	Commercial Grade	Provides 8-ohm load for amplifier output termination.
Output load (4 ohms, $\pm 1\%$ 100W)	Commercial Grade	Provides 4-ohm load for amplifier output termination.

Table 1. Test Equipment Required for Servicing

3. AM ALIGNMENT PROCEDURE

3.1 AM IF Alignment

1. Connect a sweep generator to the J153 and an alignment scope to the test point B.
2. Rotate each core of IF transformer L153 for maximum height and flat top symmetrical response.

3.2 AM Frequency Range and Tracking Alignment

1. Set AM signal generator to 515 KHz. Turn the tuning capacitor fully closed (place the tuning pointer at the low end) and adjust the oscillator coil L152 for maximum audio output.
2. Set the signal generator to 1650 KHz. Place the tuning pointer in the high frequency end and adjust the oscillator trimmer on the oscillator tuning capacitor for maximum audio output.
3. Repeat steps 1 and 2 until no further adjustment is necessary.
4. Set the generator to 600 KHz and tune the receiver to the same frequency and adjust a slug core of AM ferrite rod antenna and RF coil L151 for maximum output.

5. Set the generator to 1400 KHz and tune the receiver to the same frequency and adjust both trimming capacitors of antenna and RF tuned circuit for maximum output.
6. Repeat steps 4 and 5 until no further adjustment is necessary.

Note: During tracking alignment reduce the signal generator output as necessary to avoid AGC action.

3.3 AM Signal Strength Meter Alignment

Set an AM signal generator to 1000 KHz at $5\text{K}\mu\text{V}$, and adjust R178 so that the signal strength meter may read 90% of the full scale.

4. FM ALIGNMENT PROCEDURE

1. Connect an FM signal generator to the FM ANTENNA terminals and an oscilloscope and an audio distortion analyzer to the TAPE OUTPUT jacks on the rear panel.
2. Set the FM SG to 87 MHz and provide about 3 to $5\mu\text{V}$. Place the tuning pointer at the low frequency end by rotating the tuning knob and adjust the core of oscillator coil L104 to obtain maximum audio output.
3. Set the FM SG to 109 MHz and provide about 3 to $5\mu\text{V}$ output. Rotate the tuning knob and place the tuning pointer at the high frequency end and adjust the trimming capacitor C106 for maximum output.
4. Repeat steps 2 and 3 until no further adjustment is necessary.
5. Set the FM SG to 90 MHz and tune the receiver to the same frequency. Decrease signal generator output until the audio output level decreases with the decreasing generator output. Adjust the antenna coil L101, RF coil L102 and L103 and IF transformer L105 for minimum audio distortion.
6. Set the FM SG to 106 MHz and tune the receiver to the same frequency. Adjust the trimming capacitor C102, C104 and C105 for minimum distortion.
7. Repeat steps 5 and 6 until no further adjustment is necessary.
8. Adjust the secondary core (upper) of discriminator transformer L201 so that the center tuning meter pointer indicates its center at no signal applied. Set the FM SG to 98 MHz and increase its output level $1\text{K}\mu\text{V}$ and tune the receiver to the same frequency so that the center tuning meter pointer indicates its center.
Adjust the primary core (lower) of L201 for minimum distortion.
9. Set the FM SG to 98 MHz at $100\text{K}\mu\text{V}$, and adjust R374 so that the signal strength meter may read 90% of the full scale.

5. STEREO SEPARATION ALIGNMENT

1. Set the FM SG to provide $1\text{K}\mu\text{V}$ at 98 MHz. Tune the receiver to the same frequency so that the center tuning meter pointer indicates its center.
2. Turn the FM SG modulation off (with the pilot signal turned off), connect a frequency counter to test point J310, and adjust R311 so that the frequency counter may precisely read 19 KHz.
3. Modulate the FM SG with stereo composite signal consisting only of subchannel signal (of course a pilot signal must be included).
4. Adjust the trimming resistor R301 for maximum and same separation in both channels.

6. MUTING CIRCUIT ALIGNMENT

1. Connect a VTVM across the resistor R363 and adjust the resistor R363 until the meter reads 0.75V DC at no signal.
2. Set the FM SG to provide $1\text{K}\mu\text{V}$ at 98 MHz and tune the receiver to the same frequency correctly.
3. Turn on MUTING push switch. Shift the FM signal generator frequency to plus and minus and note both plus and minus shifted frequencies at which undesirable audio side responses are muted out. Adjust the R363 so that the same shifted frequencies mute the undesirable side response.

4. Adjust R362 for proper frequency shift at which the muting circuit operates.

7. DOLBY FM TAPE OUTPUT SETTING

1. Set the modulation of FM SG to 400 Hz, 50% (± 37.5 KHz Dev.)
2. Set the FM SG to provide 1 $K\mu V$ at 98 MHz. Tune the receiver to the same frequency so that the center tuning meter pointer indicates its center.
3. Turn on DOLBY FM push switch. Set the semifixed resistors RC01 and RC02 so that the output of the TAPE OUTPUT terminals R and L become 580 mV at VTVM.

8. AUDIO ADJUSTMENT

1. Voltage adjustment
Connect a DC voltmeter between pin terminal 804 and 805, and adjust the trimming resistor R806 for 35V DC.
2. Main Amplifier DC off-set alignment
Connect a DC voltmeter with 0.5 or 1V range between the speaker terminals and adjust the trimming resistor R707 for "zero" DC output on the meter.
Repeat the same procedure for the other channel.
Note: During this alignment no load should be connected to the speaker terminals.
3. Idle-current adjustment
Connect a VTVM between pin terminals 708 and 710. Next, adjust the trimming resistor R719 so the VTVM reads 8mV DC. Repeat the same procedure for the other channel.
4. Check DC off-set voltage aligned in the procedure 2 and if any DC output is observed on the DC voltmeter, adjust the R707 again for "zero" output.
5. Phono-amplifier adjustment
Connect an oscilloscope to the TAPE OUT jacks and an audio signal generator to the PHONO jacks. Place the selector switch in the PHONO position. Increase 1 KHz audio signal gradually until a slight clipping on top of the sine-wave is observed on the oscilloscope. Adjust the trimming resistor R408 for equal clipping level.
For the other channel adjust R409.

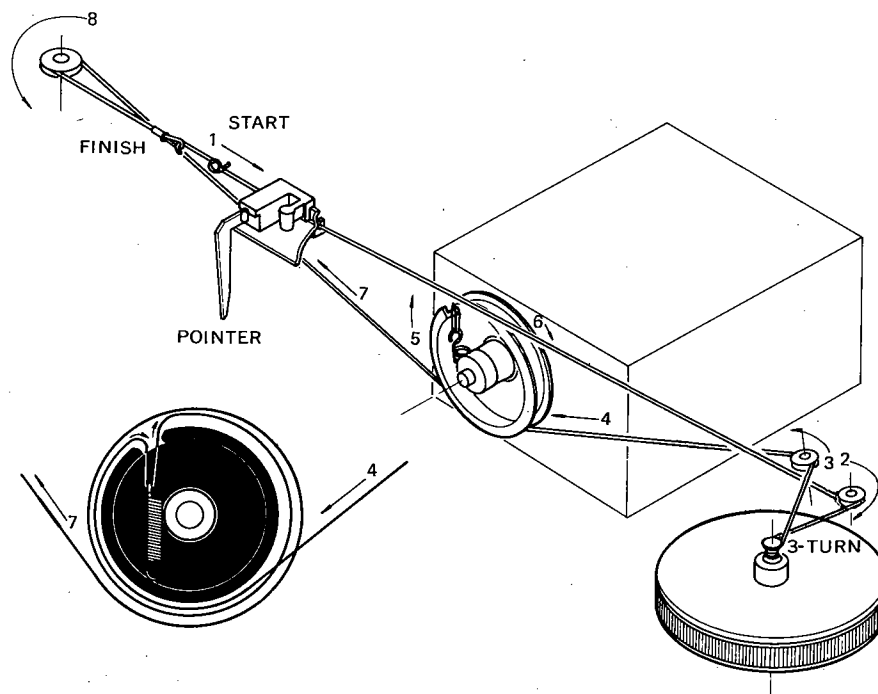

Figure 1. Dial Stringing

